

# DURA LAMP

09UT24 VV XX

09UT24: Strice professionali / Profesional strip						
VV: Volt	09 = 9W/m		14 = 14W/m			
XX: Kelvin	27 = 2700K	30 = 3000K	35 = 3500K	40 = 4000K	60 = 6000K	65 = 6500K

Questi prodotti contengono una sorgente luminosa di classe di efficienza energetica "G".\*  
 These products contain a light source of energy efficiency class "G".\*  
 Ces produits contiennent une source lumineuse de classe d'efficacité énergétique "G".\*  
 Estos productos contienen una fuente luminosa de la clase de eficiencia energética "G".\*  
 Diese Produkte enthalten eine Lichtquelle der Energieeffizienzklasse "G".\*  
 Estes produtos contém uma fonte de luz da classe de eficiência energética "G".\*

\*09UT240940, 09UT240965, 09UT241465 = "F"

09UT24 VV ZZ

09UT24: Strice professionali / Profesional strip										
VV: Volt	09 = 9W/m			14 = 14W/m						
ZZ: Colore Color	RD = Rosso Red	VR = Verde Green	GL = Giallo Yellow	OR = Arancio Orange	BL = Blue Blu	AM = Amaranto Amaranth	PI = Rosa Pink	RGB = RGB		

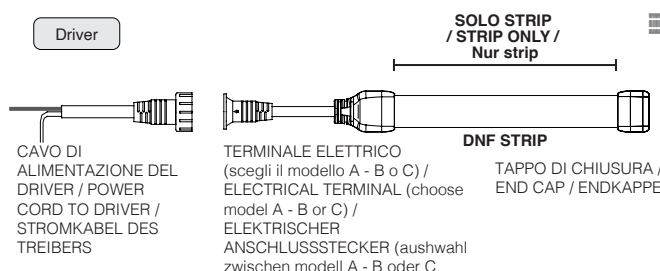

RG0

DURANEONFLEX COMPLETO CON TERMINALE A  
 DURANEONFLEX COMPLETE WITH TERMINAL A  
 DURANEONFLEX inklusive Anschlussstecker A

RG0 secondo norma IEC/TR 62778:2014 / RG0 in accordance with IEC/TR 62778:2014  
 RG0 según la norma IEC/TR 62778:2014 / RG0 selon la norme IEC/TR 62778:2014  
 RG0 de acordo com a norma IEC/TR 62778:2014 / RG0 nach der norm IEC/TR 62778:2014  
 RG0 i henhold til standarden IEC/TR 62778:2014

Dura Lamp SRL  
 Via Pratese, 164 - 50145 Florence - Italy

## DURANEON TOP FLEX

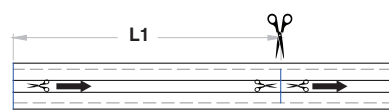
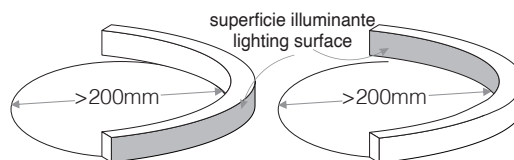
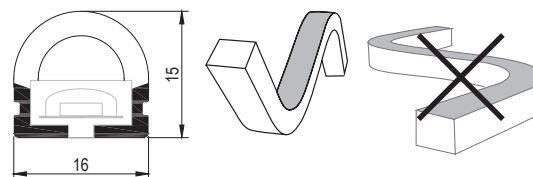

L1 = lunghezza minima di taglio/  
 minimum cutting length

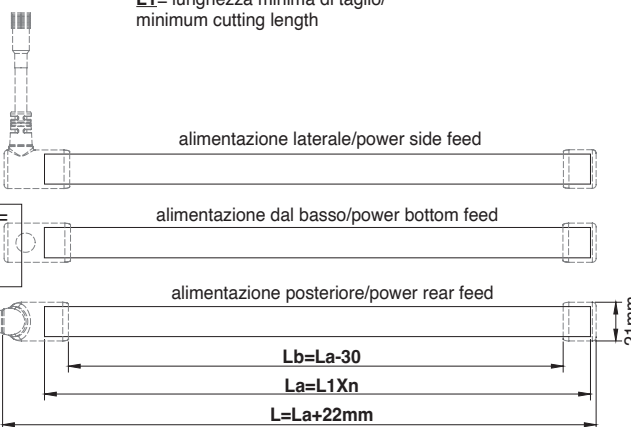

La: lunghezza determinata secondo le esigenze/  
 certain length as required

Lb: lunghezza di illuminazione/lighting length  
 n: tempi integrali di L1/integral times of L1

Nota: lo stesso metodo di taglio e di calcolo per tutti i tipi di alimentazione elettrica finale, laterale o posteriore.

Nota: same cutting and calculation way for all kinds of power feed methods in end feed, side feed and rear feed.

L - L'APPARECCHIO DEVE ESSERE INSTALLATO DA PERSONALE QUALIFICATO. VERIFICARE CHE IL PRODOTTO SIA INSTALLATO PRIMA DI CONNETTERLO ALL'ELETTRICITÀ. NON UTILIZZARE ALCUN OGGETTO PER COPRIRE LA LAMPADA. NON USARE LA LAMPADA IN AMBIENTI ERMETICI. LA MANUTENZIONE DEVE ESSERE EFFETTUATA SOLO DA UN TECNICO PROFESSIONISTA. L'AZIENDA SI RISERVA IL DIRITTO DI APPORTARE, IN QUALUNQUE MOMENTO, MODIFICHE AI PROPRI PRODOTTI, PER RAGIONI DI NATURA TECNICA O COMMERCIALE. SE IL CAVO FLESSIBILE ESTERNO O IL CAVO DI QUESTO APPARECCHIO SONO DANNEGGIATI, DEVONO ESSERE SOSTITUITI ESCLUSIVAMENTE DAL COSTRUTTORE O DA PERSONA QUALIFICATA. L'AZIENDA DECLINA OGNI RESPONSABILITÀ QUALORA L'INSTALLAZIONE NON AVVENGA SECONDO LE NORME VIGENTI. LASCIARE UNA COPIA DI QUESTE ISTRUZIONI AL RESPONSABILE DELLA MANUTENZIONE. CONSERVARE L'ETICHETTA DELL'IMBALLO ORIGINALE PER EVENTUALI RECLAMI FUTURI.

GB - THIS FIXTURE MUST BE INSTALLED BY A QUALIFICATED ELECTRICIAN. MAKE SURE THAT THE PRODUCT IS INSTALLED BEFORE PLUG IN DON'T USE ANY OBJECT TO COVER THE LAMP. DON'T USE THE LAMP IN AIR-TIGHT ENVIRONMENTS. MAINTENANCE SHOULD ONLY BE DONE BY A PROFESSIONAL TECHNICIAN. IN CASE OF ANY CHANGE TO THE PRODUCT WE RETAIN THE RIGHT TO INFORM YOU IN ADVANCE IF THE EXTERNAL FLEXIBLE CABLE OR CORD OF THIS LUMINAIRE IS DAMAGED, IT SHALL BE EXCLUSIVELY REPLACED BY THE MANUFACTURER OR HIS SERVICE AGENT OR A SIMILAR QUALIFIED PERSON IN ORDER TO AVOID A HAZARD. DURALAMP IS NOT RESPONSIBLE IF ITS FIXTURES ARE NOT INSTALLED ACCORDING TO LOCAL SAFETY STANDARDS. PLEASE LEAVE A COPY OF THESE INSTRUCTIONS TO THE PERSON RESPONSIBLE FOR THE MAINTENANCE OF THE INSTALLATION. KEEP THE LABEL OF THE ORIGINAL PACKING FOR THE EVENTUAL FUTURE CLAIMS

D - DIE INSTALLATION MUSS VON EINEM QUALIFIZIERTEN FACHPERSONAL DURCHFEGÜHRT WERDEN. STELLEN SIE SICHER, DASS DAS GERÄT ORDNUNGSGEMÄß INSTALLIERT WIRD, BEVOR SIE DEN STECKER EINSTECKEN. DECKEN SIE DIE LAMPE NIEMALS AB. BENUTZEN SIE DIE LAMPE NICHT IN LUFTDICHTEN RÄUMEN. WARTUNGSARBEITEN DÜRFEN NUR DURCH EINE QUALIFIZIERTE PERSON DURCHGEFÜHRT WERDEN. IN FALLE EINER PRODUKTÄNDERUNG BEHALTET SICH DURALAMP DAS RECHT VOR SIE VORAB ZU INFORMIEREN. BEI DEINEM DEFEKT DER ANSCHLUSSLEITUNG MUSS DIESER VOM HERSTELLER, EINEM SERVICEUNTERNEHMEN ODER EINEM FACHPERSONAL BEHOBBEN WERDEN. DURALAMP IST NICHT VERANTWORTLICH WENN DIE MONTAGE NICHT GEMÄSS DEN SICHERHEITSVORSCHRIFTEN STATTFINDET. DIESES HINWEISBLATT MUSS VOM INSTANDHALTUNGSLERER AUFBEWAHRT WERDEN. BEI REKLAMATIONEN BITTE DEN ARTIKELAUFLIEBER AUS DER LEUCHTENVERPACKUNG BEIFÜGEN.

S - ARMATUREN MÄSTE INSTALLERAS AV GODKÄND ELEKTRIKER. DURALAMP KAN INTE PÅTTAGES NÅGOT ANSVAR FÖR ATT PRODUKTEN INTE INSTALLERATS ENLIGT GÄLLANDE BESTÄMMELSER VÄNLIGEN ÖVERLÄMNA DESSA INSTRUKTIONER TILL ANSVARIG FÖR INSTALLATIONEN. BEHÅLL ORIGINALKETTEN PÅ FÖRPACKNINGEN FÖR EVENTUELLA REKLAMATIONER.

F - L'APPAREIL DOIT ETRE INSTALLE PAR ELECTRICIENS QUALIFIES. DURALAMP NE PEUT PAS ETRE RESPONSABLE POUR TOUTES INSTALLATIONS QUI NE RESPECTENT PAS LES NORMES DE SECURITE EN VIGUER. LAISSER UNE COPIE DE CES INSTRUCTIONS AU RESPONSABLE DE L'ENTRETIEN DU SYSTEME. GARDER L'ETIQUETTE DE L'EMBALLAGE ORIGINAL POUR EVENTUELLES RECLAMATIONS FUTURES.

E - EL APARATO DEBE SER INSTALADO POR ELECTRICISTAS CUALIFICADOS. DURALAMP NO SE RESPONSABILIZARA DE TODAS LAS INSTALACIONES QUE NO RESPETEN LAS NORMAS DA SEGURIDAD EN VIGOR. ENTREGAR UNA COPIA DE ESTAS INSTRUCCIONES AL RESPONSABLE DE LA INSTALACION. CONSERVAR LA ETIQUETA DEL EMBALAJE ORIGINAL PARA POSIBLES RECLAMACIONES.

SL - PRIKLOP SVETILKE MORA IZVEST POOBLAŠEENA OSEBA. PRED PRIKLOPOM NA ELEKTRIENO OMRZEJE JE POTREBNO NAJPREJ MONTIRAT SVETILKO NA STROP/STENO. V KOLIKOR JE MONTAZA IZVEDENA S STRANI NEPOOBLAŠEENE OSEBE ODGOVORNOST UVOZNIKA IN PROIZVAJALCA POSTANE NIENA. VEDNO JE POTREBNO SHRANITI KOPIJO NAVODIL ZA MONTAZO ZA KASNEJSI VPOGLED S STRANI VZDRZEVALCEV.

PT - O APARELHO DEVE SER INSTALADO POR PESSOAL QUALIFICADO. VERIFICAR SE O PRODUTO ESTÁ INSTALADO ANTES DE O CONEXAR COM A ELECTRICIDADE. NÃO UTILIZAR QUALQUER OBJECTO PARA COBRIR A LÂMPADA. NÃO UTILIZAR A LÂMPADA NUM AMBIENTE HERMÉTICO. A MANUTENÇÃO DEVE SER REALIZADA APENAS POR UM TECNICO PROFISSIONAL. A EMPRESA RESERVA-SE O DIREITO DE FAZER ALTERAÇÕES AOS SEUS PRODUTOS EM QUALQUER ALTURA POR RAZÕES TÉCNICAS OU COMERCIAIS. SE O CABO FLEXIVEL EXTERNO OU O CABO DESTE APARELHO FOR DANIFICADO, SÓ DEVE SER SUBSTITUÍDO PELO FABRICANTE OU POR UMA PESSOA QUALIFICADA. A EMPRESA DECLINA TODA A RESPONSABILIDADE SE A INSTALAÇÃO NÃO FOR REALIZADA DE ACORDO COM AS NORMAS ACTUAIS. DEIXAR UMA COPIA DESTAS INSTRUÇÕES COM A PESSOA ENCARGADA DA MANUTENÇÃO. MANTER O ROTULO DA EMBALAGEM ORIGINAL PARA FUTURAS ALEGAÇÕES.



Filippi TARGETTI  
 GROUP

www.duralamp.com

rel 19\_0324

## Installazione TOP Flex Strips/TOP Flex Strips Installation:

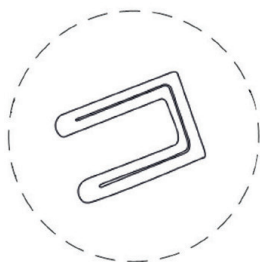

Protezione del chip LED / PCB protection.

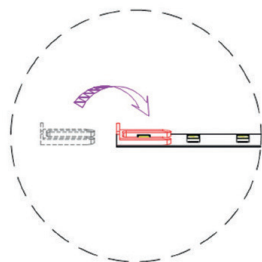

Inserire la protezione sopra alla striscia per evitare lo schiacciamento del chip/ Insert protection on the strip to avoid chip crushing.

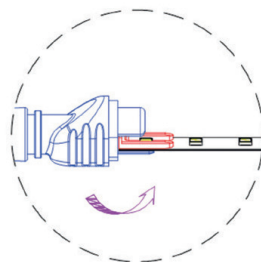

Inserire il connettore sul retro della striscia (se inserito sopra alla striscia si danneggia il LED) / Insert the connector on the back of the strip ( if it is inserted above the strip, the LED will be damaged).

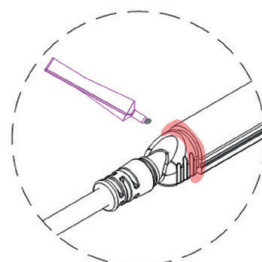

Aggiungere la colla nell' apposita scanalatura per sigillare / Seal the item by adding glue into the groove

**IT** - Cavi liberi. Necessita di morsetteria conforme alla norma EN60998-2-1 o EN60998-2-2, con le seguenti caratteristiche: terminale a 2 vie + e - 24Vdc ; o min 1,0mm; per installazione indipendente. IP65

**ENG** - Screwless terminal, terminal block not included. To be provided with screw terminal block conform to EN60998-2-1 or EN60998-2-2, with the following characteristics: 2 ways terminal, +and -; 24V o min.1,0mm; for independent installation. IP65

**FR** - Câbles libres. Nécessite un bornier conforme à la norme EN60998-2-1 ou EN60998-2-2, avec les caractéristiques suivantes : borne à 2 voies + et - 24Vdc ; o min 1,0mm ; pour installation autonome. IP65

**ES** - Cables libres.Necesita de un terminal conforme con la norma EN60998-2-1 o EN60998-2-2, con las siguientes características: terminal de 2-vias (+ y-); 24V y o min. 1.0 mm, para su instalación independiente. IP65

**PT** - Cabos livres. Requer bloco de terminais em conformidade com a norma EN60998-2-1 ou EN60998-2-2, com as seguintes características: terminal de 2 vias + e - 24Vdc; o min 1,0mm; para instalação independente. IP65

**DE** - Elektrischer Anschluss über freie Kabelenden, Klemme Bauseits. Verwendete Schraubklemmen müssen der Norm EN60998-2-1 oder EN60998-2-2 entsprechen und folgende Merkmale aufweisen: 2 Leiter Trennung (+ und -); 240 Volt; Min. o1,0mm ; für ortsunabhängige Montage verwendbar. IP65

**DA** - Frie kabler. Kræver terminalblok i overensstemmelse med EN60998-2-1 eller EN60998-2-2, med følgende egenskaber: 2-vejs terminal + og - 24Vdc ; o min 1,0mm; til fritstående installation. IP65

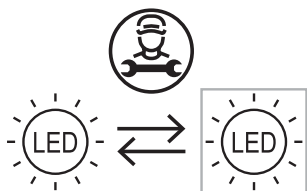

## KIT accesories DURANEONFLEX



**KT09UVL1**

Terminale in linea per Vert flex / Streight terminal for Vert flex / Terminal en línea para Vert flex / Terminaison en ligne pour Vert flex / Anschluss in Reihen-verbund für Vert flex



**KT09UVL2**

Terminale laterale per Vert flex / Lateral terminal for Vert flex / Terminal lateral para Vert flex / Terminaison en ligne pour Top flex / Seitlicher Anschluss für Vert flex



**KT09UVL3**

Terminal for Vert flex / Terminal inferior para Vert flex / Terminaison inférieure pour Vert flex / Anschluss unten für Vert flex

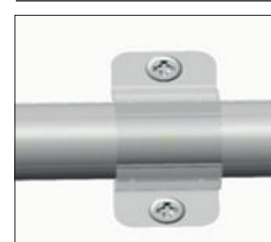

**KT09UVS1**

Clip di fissaggio per Vert flex / Fixing clips for Vert flex / Clip de fijación para Vert flex / Clip de fixation pour Vert flex / Befestigungsclips für Vert flex



**KT09UTL1**

Clip di fissaggio per Top flex / Fixing clips for Top flex / Clip de fijación para Top flex / Clip de fixation pour Vert flex / Befestigungsclips für Top flex

**A = Terminale in Linea**  
**A = Line/Straight Terminal**

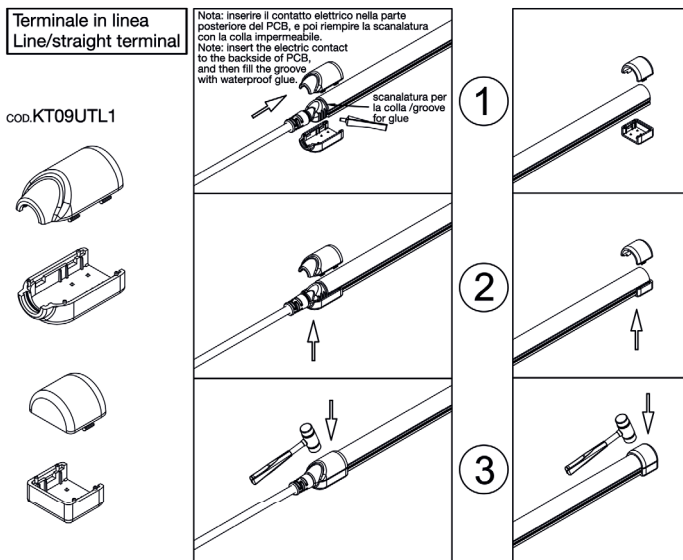

**B = Terminale Laterale**  
**B = Side/Lateral Terminal**

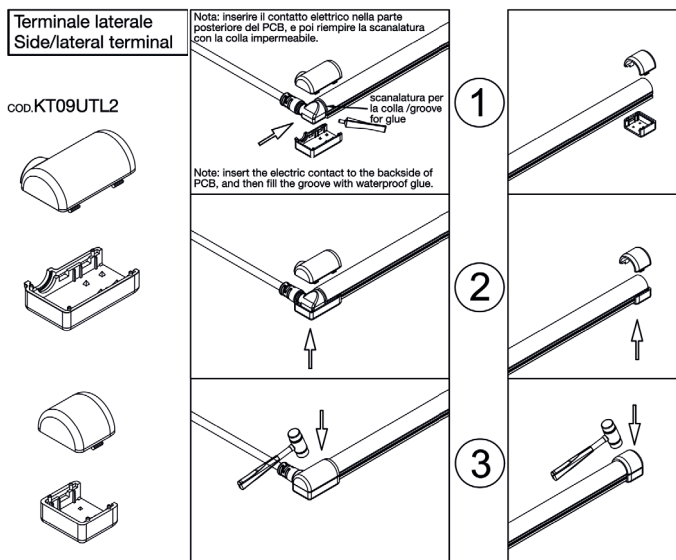

**C = Terminale Posteriore**  
**C = Rear/Bottom Terminal**

